

TR Series Temperature Controller Manual



Features:

- Universal input: RTD, TC, Analog Signal, selected by software.
- Function: Displaying, Alarm and Adjusting.
- Advanced Two Degrees of Freedom PID Arithmetic
- Auto-tuning PID function for different systems (Increasing/Decreasing temperature quickly, Heating system with low speed).
- Optional control output, modularization design.
- High anti-interference.
- Switching Power Supply (SPS) is 100-240VAC.
- Applied to system temperature control.

For your safe, please read the below content carefully before you use the temperature controller!

■ Safe Caution

※ Please read the manual carefully before you use the temperature controller!

※ Please comply with the below important points:

⚠ Warning An accident may happen if the operation does not comply with the instruction.

⚠ Notice An operation that does not comply with the instruction may lead to product damage.

※ The instruction of the symbol in the manual is as below:

⚠ An accident danger may happen in a special condition.

⚠ Warning

1. A safety protection equipment must be installed or please contact with us for the relative information if the product is used under the circumstance such as nuclear control, medical treatment equipment, automobile, train, airplane, aviation, entertainment or safety equipment, etc. Otherwise, it may cause serious loss, fire or person injury.
2. A panel must be installed, otherwise it may cause creepage (leakage).
3. Do not touch wire connectors when the power is on, otherwise you may get an electric shock.
4. Do not dismantle or modify the product. If you have to do so, please contact with us first. Otherwise it may cause electric shock and fire.
5. Please check the connection number while you connect the power supply wire or input signal, otherwise it may cause fire.

⚠ Caution

1. This product cannot be used outdoors. Otherwise the working life of the product will become shorter, or an electric shock accident may happen.
2. When you connect wire to the power input connectors or signal input connectors, the moment of the No.20 AWG (0.50 mm²) screw tweaked to the connector is 0.74n.m - 0.9n.m. Otherwise the connectors may be damaged or get fire.
3. Please comply with the rated specification. Otherwise it may cause fire after the working life of the product becomes shorter.
4. Do not use water or oil base cleaner to clean the product. Otherwise it may cause electric shock or fire, and damage the product.
5. This product should be avoid working under the circumstance that is flammable, explosive, moist, under sunshine, heat radiation and vibration. Otherwise it may cause explosion.
6. In this unit it must not have dust or deposit, otherwise it may cause fire or mechanical malfunction.
7. Do not use gasoline, chemical solvent to clean the cover of the product because such solvent can damage it. Please use some soft cloth with water or alcohol to clean the plastic cover.

1) Model

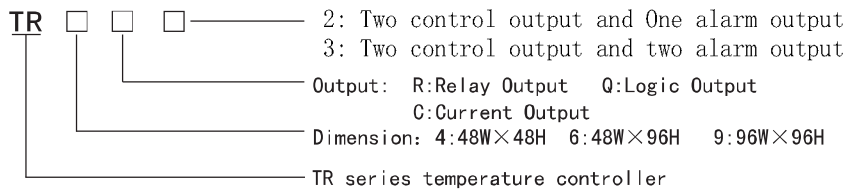

2) Model Indication

Model	Alarm Number	Control Output	Alarm Output	Dimension (mm)
TR4-R2	1	Relay Output	Relay Output	48Hx48WX78L
TR4-Q2	1	Logic Output	Relay Output	48Hx48WX78L
TR4 (special order)	2	Relay or Logic Output	Relay Output	48Hx48WX78L
TR6-R3	2	Relay Output	Relay Output	96Hx48WX78L
TR6-Q3	2	Logic Output	Relay Output	96Hx48WX78L
TR6-C3	2	Current Output	Relay Output	96Hx48WX78L
TR9-R3	2	Relay Output	Relay Output	96Hx96WX78L
TR9-Q3	2	Logic Output	Relay Output	96Hx96WX78L
TR9-C3	2	Current Output	Relay Output	96Hx96WX78L

3) Primary Technical Parameters

1. Parameters for whole controller

Total Voltage	100-240VAC
Total Current	<30mA (220VAC)
Ambient Temperature	0-50℃
Ambient Humidity	45-85RH%

2. Input

Code	Input Type	Measure Range	Resolution	Accuracy	Input Impedance
0	TC Type S	0-1600℃	1℃	0.5%FS±3digits	>100KΩ
1	TC Type B	200-1800℃	1℃	0.5%FS±3digits	>100KΩ
2	TC Type K	0-1300℃	1℃	0.5%FS±3digits	>100KΩ
3	TC Type E	0-600℃	1℃	0.5%FS±3digits	>100KΩ
4	TC Type T	0-300℃	1℃	0.5%FS±2digits	>100KΩ
5	TC Type J	0-800℃	1℃	0.5%FS±3digits	>100KΩ
6	Reservation				
7	PT100 High Temperature	-200-800℃	0.1℃	0.5%FS±2digits	(0.2mA)
8	PT100 Low Temperature	-200-200℃	0.1℃	0.5%FS±1digits	(0.2mA)
9	CU50	-50-150℃	0.1℃	0.5%FS±1digits	(0.2mA)
10	0-20mV	0-20mV	10digitsAD	0.5%FS±3digits	>100KΩ
11	0-50mV	0-50mV	10digitsAD	0.5%FS±3digits	>100KΩ
12	Linear Resistance	0-400Ω	10digitsAD	1%FS±3digits	

3. Output

Output Type		Capacity
Relay Output	OUT1	relay output, 3A/220VAC
	OUT2	relay output, 1A/220VAC
Current Output	OUT1	current output, 4mA-20mA, load resistance 600Ω
	OUT2	relay output, 1A/220VAC
Logic Output	OUT1	24V Voltage, with load 30mA
	OUT2	relay output, 1A/220VAC

※ Note: When the controller is set as heating-cooling control, OUT1 cannot be current output.

4) Panel

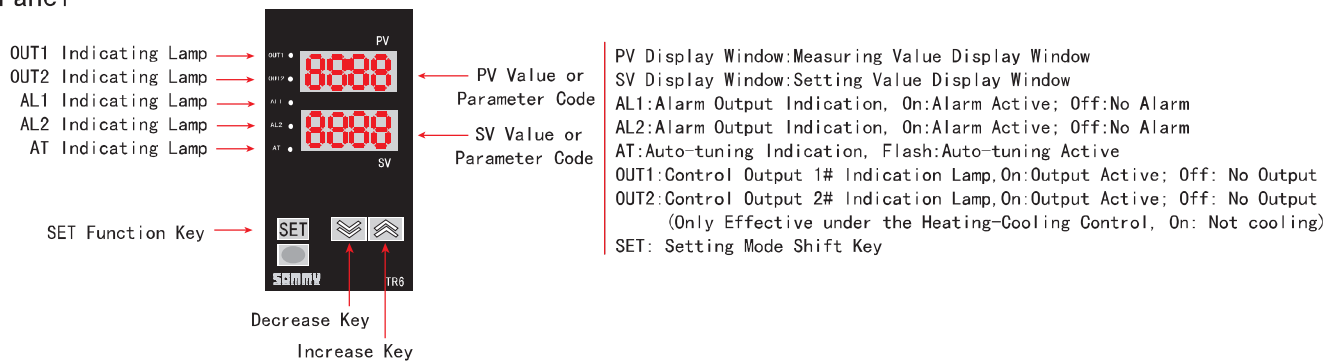

1 Panel Key Operation

- (1) SET Key: In normal display status, press SET Key to enter SV setting menu, press SET key for a few seconds to enter setting menu.
- (2) ▲▼ Key: Press them to set the value in the SV value menu or setting menu.
- (3) ▲ Key: In normal display status, press it for a few seconds to enter Auto-tuning which is applied to quick heating & cooling system. (For increasing temperature quickly)
- (4) ▼ Key: In normal display status, press it for a few seconds to enter Auto-tuning which is applied to slow heating & cooling system. (For small overshoot)

2 P.I.D parameters setting & Auto-tuning operation

- (1) To set P.I.D parameters manually:

The default PID value has been pre-set when the product is ex-factory. This PID value is applicable to normal heating/cooling system for temperature control. If the temperature control performance is not very good when using the default PID value, the value can be changed according to the experience for those users who have the automation control theory & experience.

- (2) To set P.I.D parameters automatically:

If users do not know how to set the PID value, they can use the Auto-tuning function of the product. The Auto-tuning function will calculate the P, I, D value it needs automatically as per different heating systems of users, and then adjust and control temperature automatically as per the calculated PID value.

Auto-tuning method: At first set the SV value, then press ▲ key or ▼ key for more than 3 seconds. Wait until the AT indicating lamp turning on, then release pressing. AT indicating lamp ON means Auto-tuning is running.

Please do not change SV value or other parameters on the controller to make sure the Auto-tuning gets an accuracy result. After the AT lamp turns off, the controller will refresh the P, I, D value automatically.

At this time, the controller can control temperature automatically and precisely.

5) Operation Sequence

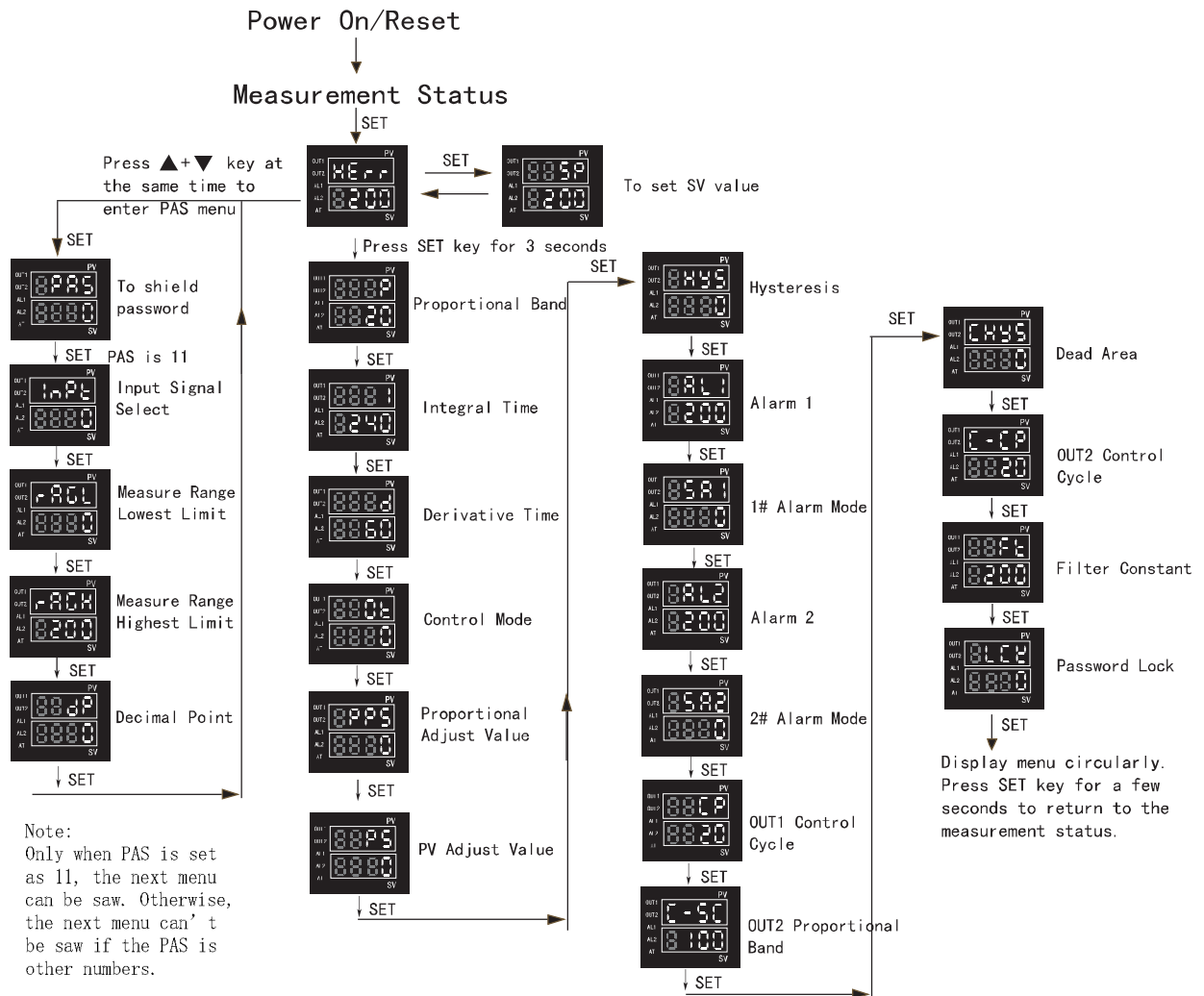

7) PID Control Menu

Parameter	Indication	Setting Range	Ex-Factory Setting
P	Proportional Band. The smaller the proportional band is, the faster the system heats. Instead, the slower the system heats. Increase the proportional band will decrease the oscillation, but increase control tolerance. Decrease the proportional band will decrease the control tolerance, but cause oscillation.	0-Highest Limit	20
I	Integral Time. The smaller the integral time is, the stronger the integral action is and better for eliminating the tolerance between it and the setting value. If the integral time is too short, it may not eliminate the tolerance.	0-3600S	240
d	Derivative Time. To decrease the derivative time to a proper value can prevent the system from oscillating. The bigger the D is, the stronger the derivative action is.	0-3600S	60
mode	0:Proportional Control 1:Heating Control 2:Cooling (OUT1 Cooling) Control 3:Heating-Cooling Control (OUT1 Heating/OUT2 Cooling)	0-3	1
PPS	Proportional Amend Value applied to adjust static tolerance.	0-10	0
PS	PV value amending applied to amend the tolerance caused by measuring process.	-50-50	0
HYS	Proportional Control Hysteresis (0T is effective when it is set as 0)	0-25	0
RL1	Alarm 1# (Alarm hysteresis value is fixed at 0.6)	Lowest Limit-Highest Limit	200
SR1	Alarm 1# mode. Please refer to Alarm Parameter Table.	0-12	0
RL2	Alarm 2# (Alarm hysteresis value is fixed at 0.6) (TR4 does not have AL2)	Lowest Limit-Highest Limit	200
SR2	Alarm 2# mode. Please refer to Alarm Parameter Table. (TR4 does not have SA2)	0-6	0
CP	OUT1 Control Cycle. Relay Output>4, logic level output or pulse output must be set as 2, current output is set as 1.	1-120S	20
C-SC	Out2 output proportional band. Only effective in heating/cooling control.	1-600	20
CHYS	Dead area. When in heating/cooling control, the area that heating proportional band does not superpose cooling proportional band.	-10-10	0
C-CP	OUT2 Control Cycle. Only effective in heating/cooling control.	1-60S	20
Ft	Filter constant. The smaller Ft is, the faster response is, but may cause fluctuation.	0-255	60
LCE	0:Can change any parameters 1:Only can change SV value 2: Any change is prohibited	0-2	0

Measuring parameters setting menu

Parameter Name	Indication	Setting Range
INPT	Input signal select, please refer to input parameter table	0-12
RAGL	Measuring Range Lowest Limit	The Lowest Limit of input signal RAGH
RAGH	Measuring Range Highest Limit	RAGH-The Highest Limit of input signal
DP	0:No decimal point 1:one digital decimal 2:two digital decimal (It is not effective for TC/RTD input.)	0-2

Alarm Parameter Table

Alarm Code	Alarm Mode	Alarm Output (AL1, AL2 is independent with each other) (SA1 and SA2 are the number between 1 to 6)
1	Highest Limit Absolute Value Alarm	
2	Lowest Limit Absolute Value Alarm	
3	Highest Limit Tolerance Value Alarm	
4	Lowest Limit Tolerance Value Alarm	
5	Highest/Lowest Limit Tolerance Value Alarm	
6	Highest/Lowest Limit Interzone Value Alarm	

Alarm Parameter Table

Alarm Code	Alarm Mode	The below two sets of alarm parameters(AL1,AL2) are used together, AL1 alarm outputs (SA1 is the number between 7 to 12), SA2 must be set as 0.
7	Highest/Lowest Limit Absolute Value Interzone Alarm	
8	Highest/Lowest Limit Tolerance Value Interzone Alarm	
9	Highest Limit Absolute Value & Lowest Limit Tolerance Value Interzone Alarm	
10	Highest Limit Tolerance Value & Lowest Limit Absolute Value Interzone Alarm	
11	Highest/Lowest Limit Absolute Value Alarm	
12	Highest/Lowest Limit Tolerance Value Alarm	

9) Outlook and Installation dimension

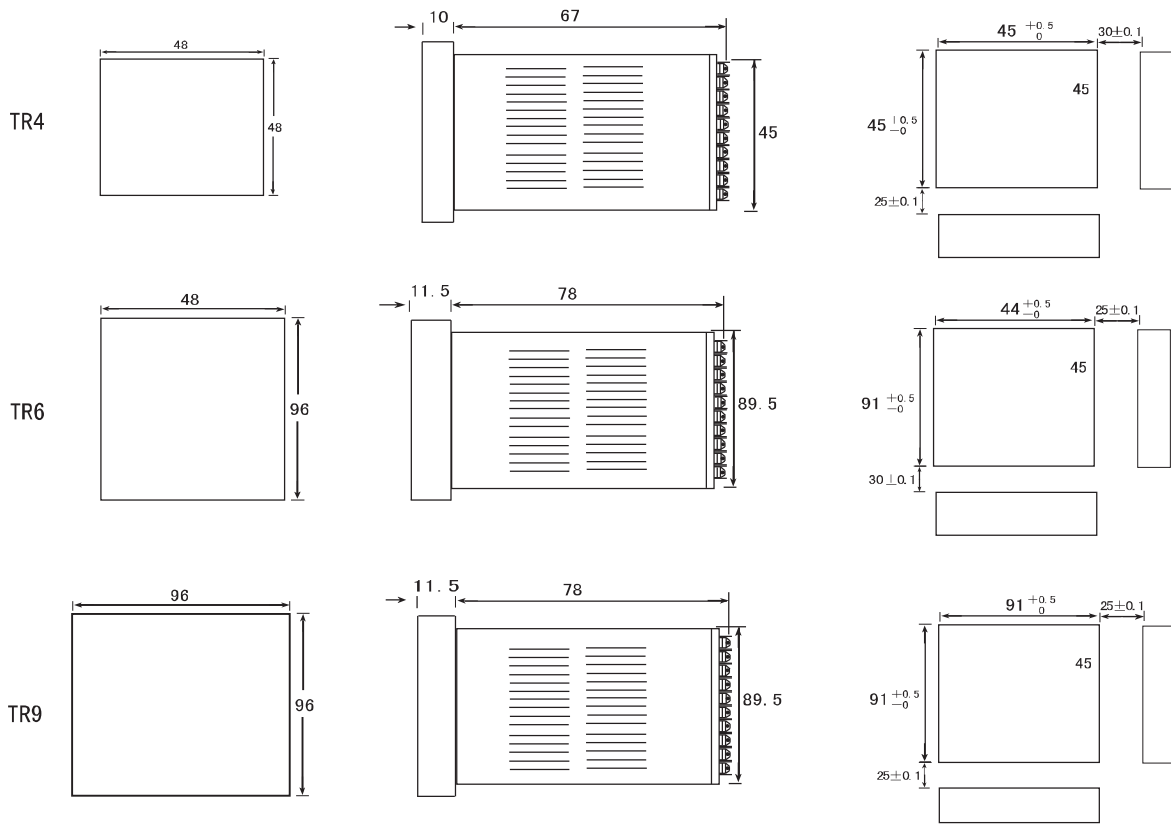

10) Connection drawing

TR9 Power Supply: AC 100V-240V
 Alarm Output: AV 250V 1A
 (Resistance Load)
 Relay Output: AC 250V 3A

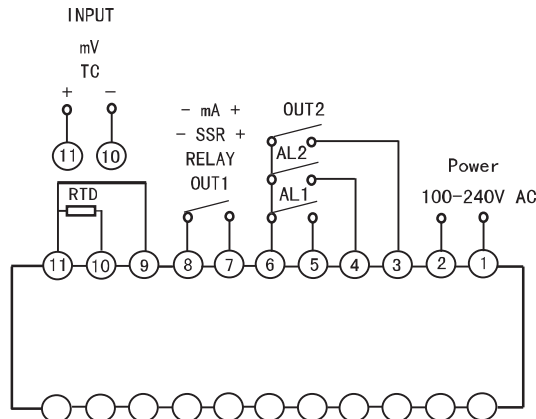

TR6 Power Supply: AC 100V-240V
 Alarm Output: AV 250V 1A
 (Resistance Load)
 Relay Output: AC 250V 3A

TR4 Power Supply: AC 100V-240V
 Alarm Output: AV 250V 1A
 (Resistance Load)
 Relay Output: AC 250V 3A

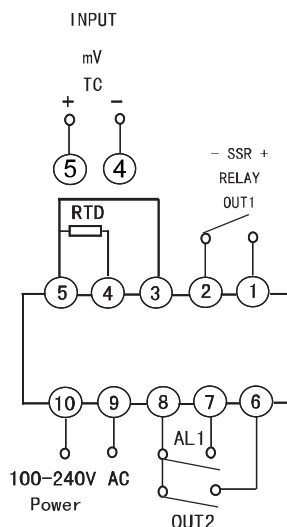
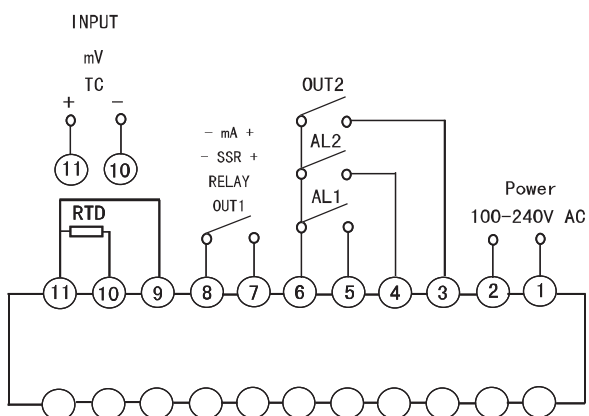

11) Simple Trouble-Shooting Method

Displaying Message	Trouble-Shooting Method
Displaying HERR	No sensor connected or input signal is higher than the highest limit. To check the input signal & RAGH value & ambient temperature.
Displaying LERR	No sensor connected or input signal is lower than the lowest limit. To check the input signal & RAGL value & ambient temperature.

Toky Electrical Co., Ltd.

Add.: Civil Science & Technology Park, No.8 Minke West Road,
 Shiqi North District, Zhongshan, Guangdong, China.

Tel.: 86-760-3371808

Fax: 86-760-8722611

Contact: Mr. River Wong

E-mail: wm@toky.com.cn